

CWS Coil Winding Specialist

Specification Sheet

Date: May 2004

Part No. : TS221-Y03

Rev. :

Product : TOPSWITCH TRANSFORMER

Comment :

Item	Printed Specification	Proposed Specification

Remark :

Engineer:

Verified:

Approved by :

CWS Coil Winding Specialist

Mechanical Dimension & Schematic

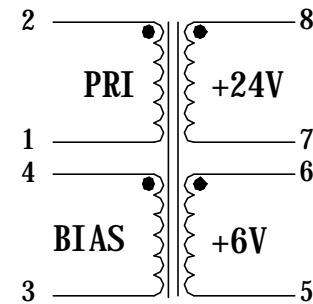
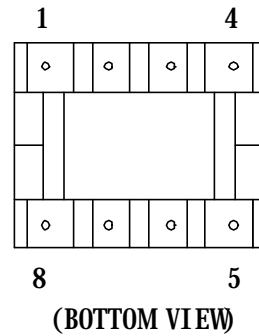
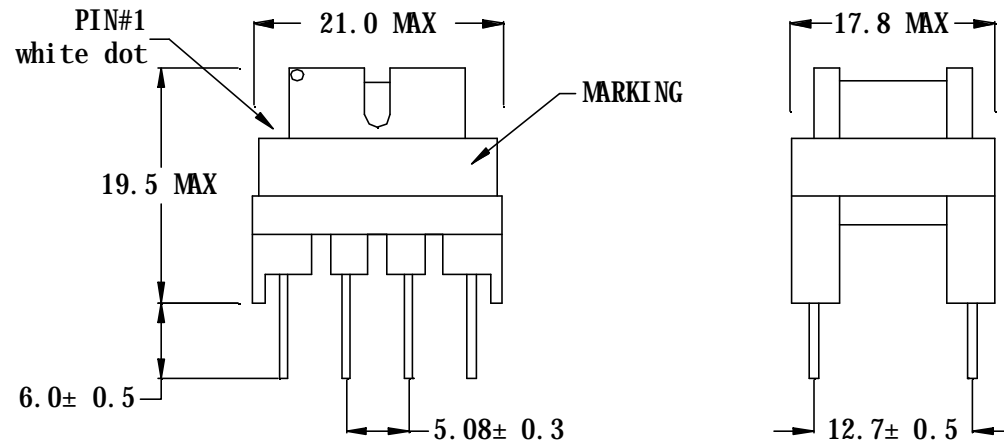

UNIT : mm

Customer :

Part No. : TS221-Y03

Rev.:

Sample No. :

CWS Coil Winding Specialist

Electrical Specification												
Remark :												
Testing Item	Specification	Pin No.	Samples Tested Data									
			1	2	3	4	5	6	7	8	9	10
INDUCTANCE WK-3245 @100KHz,0.1V	3.099 mH ±10%	L (2-1)										
LEAKAGE IND. WK-3245 @100KHz,0.1V	155.0 uH MAX PIN 5,6,7,8 SHORTED	LK (2-1)										
HI-POT TEST GPT-615	3000VAC,1mA,1sec	2,4 TO 6,8										
Customer :			Part No. : TS221-Y03				Rev.:			Sample No. :		